

IMPULS *Series*



Linear Motor Wire EDM



The YCM logo consists of the letters 'YCM' in a bold, white, sans-serif font, followed by a registered trademark symbol (®). The logo is set against a dark blue rectangular background with rounded corners. The background of the entire page is a high-contrast, black and white photograph of a wire-cut EDM machine in operation, showing a large spool of brass wire on the left and a cutting head on the right, with sparks and coolant spray visible at the cutting point.

YCM[®]

World Class CNC Machine Tool Manufacturer

A YCM Alliance Partner

Founded in 1954, the YCM company specializes in the manufacturing of CNC Machining Centers and is recognized worldwide for technological advancements, manufacturing capabilities and superior product design. Since its founding, YCM machines are relied upon by quality conscious customers who have become accustomed to their uncompromising performance and renowned reliability.

Excetek Technologies CO., LTD. a partner of YCM (Yeong Chin Machinery Industries CO., LTD.) is known for its many years of experience designing and engineering Wire-cut EDM systems. When combined with YCM's historic success building a wide range of milling machines, the result is a superior and technically advanced Wire-cut EDM product line-up that makes it a very capable contender. The merging of each companies' technologies is unique and represents a differentiated approach to machine design.



Make it Better, Together.

Quality, Performance, Reliability

The Impuls Series is specially designed for challenging wire EDM applications and are built to high quality standards providing industry leading performance and long-term reliability. Applications include a wide range of materials and components serving multiple industries.

Rigid Design

During the design process, Finite Element Analysis (FEM) is used to ensure the best placement of mass and rib structures to provide continuous stability under varying thermal and mechanical dynamics. This commitment to quality starts at the YCM foundry where components are perfectly cast resulting in a rigid Meehanite structure.

Accuracy and Precision

Advanced high thrust linear motors deliver fast, accurate, and repeatable cutting. The combination of a rigid structure, linear motors and glass scales provide uncompromising precision and accuracy to single digit micron levels and surface finishes down to Ra 0.14 μm .

Control and Generator System

A robust industrial designed PC at the front end delivers an intuitive user friendly interface that provides the flexibility for any level operator to perform the most challenging and complex parts machining with ease.

The latest advancements in digital power generation include the ability to manage cutting conditions and automatically adjust power, wire tension, and flushing parameters to reach optimum speed, accuracy and overall performance.

Make it Better, Together

IMPULS

Cutting Technology

Workpiece: SKD-11
 Thickness: 20 mm
 No. of cuts: 1 cut 2 skim

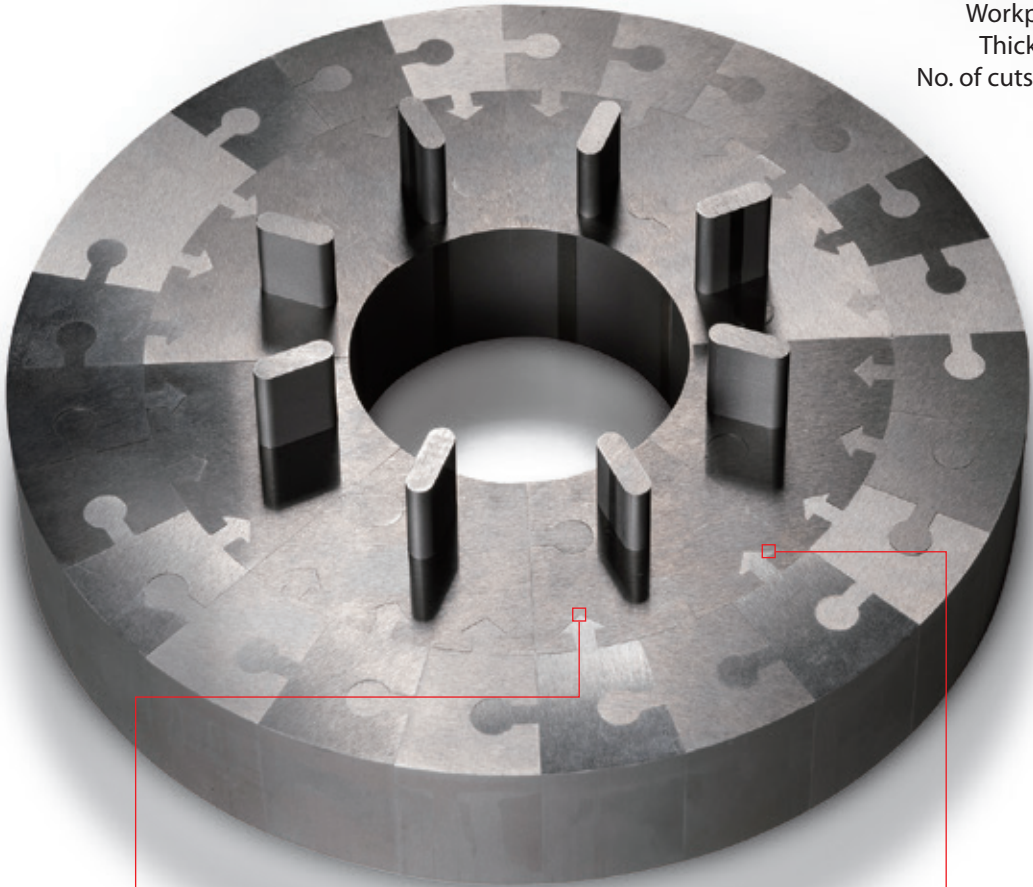

Make Better Parts

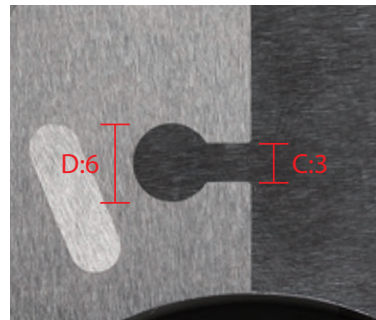
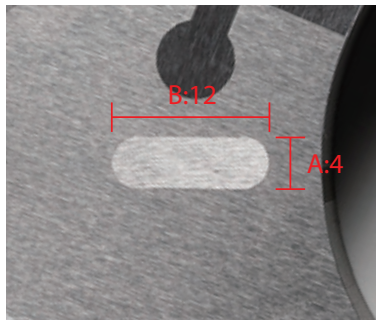
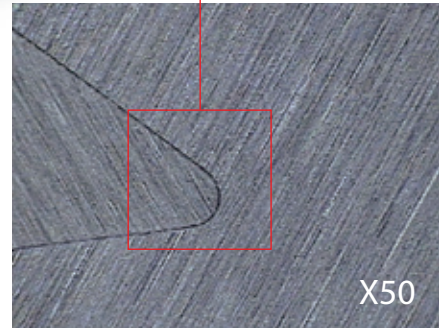
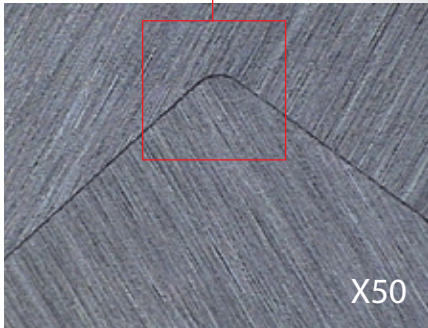

	A	B	C	D
Impuls Technology	0	0~-2 μ	0	0~-2 μ
Standard Technology	0	-8~-10 μ	0	-8~-10 μ

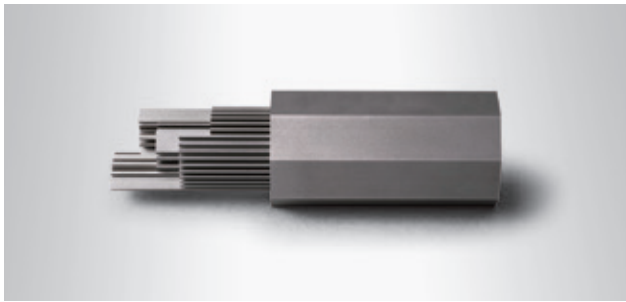

Material	SKD-11
Wire diameter / type	0.2 mm / Brass
Thickness	50 mm
No. of cuts	1 rough cut 2 skims

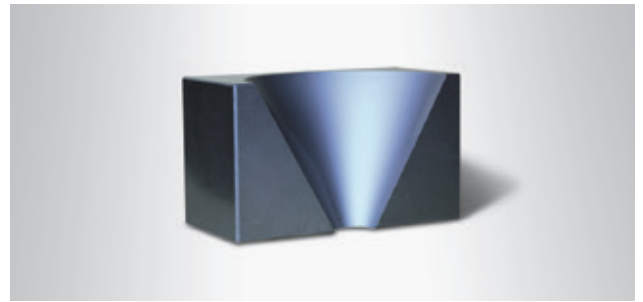

Material	SKD-11
Wire diameter / type	0.25 mm / Brass
Angle of taper	30°
Thickness	50 mm
No. of cuts	1 rough cut 3 skims

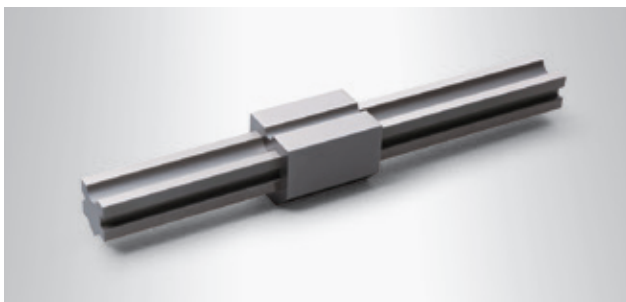

Material	SKD-11
Wire diameter / type	0.25 mm / Brass
Thickness	200 mm
No. of cuts	1 rough cut 2 skims



Material	Tungsten carbide
Wire diameter / type	0.2 mm / Brass
Thickness	50 mm
No. of cuts / finish	1 rough cut 4 skim / Ra 0.18 μm

SFC - Super Finish Circuit

Standard surface roughness Ra 0.3 μm, optional Ra 0.14 μm

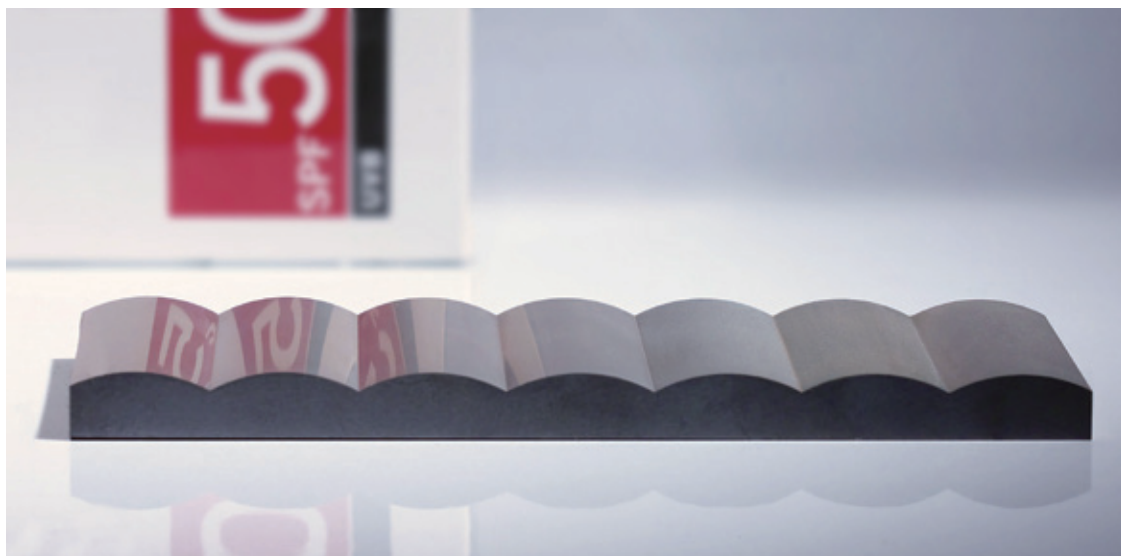

Material: Tungsten carbide
 Thickness: 30 mm (best surface roughness Ra 0.14 μm)

State of the Art Foundry

YCM Machine Tools are Built From the Ground Up

Unlike many machine tool manufacturers that purchase casting from other suppliers – YCM is a true machine tool builder that produces castings for itself and its partners. This commitment to quality begins at the YCM foundry where the heart of every Wire-cut EDM machine – the base components, are perfectly cast resulting in a rigid Meehanite® structure. This establishes a quality foundation which is precise, rigid, and very stable. This build process is inherent with every YCM Wire-cut EDM machine tool produced.



- Castings are poured at the YCM factory.
- Advanced Karl Fischer moisture and pH metering.
- Spectrum analysis to ensure consistent quality.
- Annealing and aging process to relieve casting stress.
- All mating surfaces are handcrafted.

Rigid U, V design.

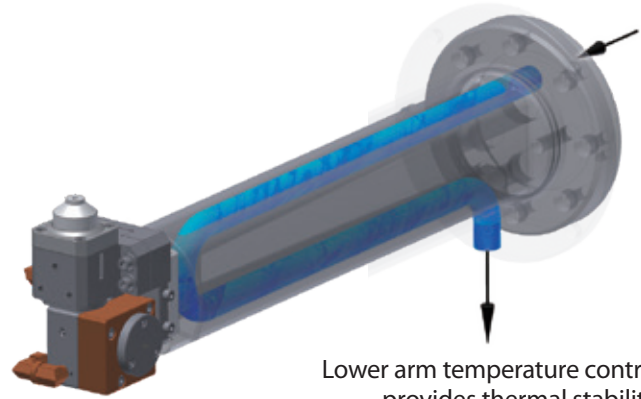
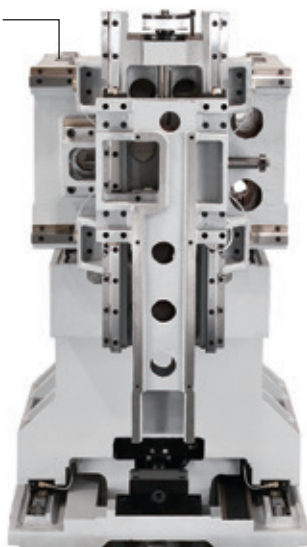

Lower arm temperature control provides thermal stability.

Four-sided hardened stainless steel table.



The height of the working table surface and Y axis guideways are the same which reduces the Abbe error.

Finite Element Method (FEM) design is used to optimize structural stability.

Extra wide machine base.





Advanced High-Thrust Linear Motors

- Advanced High-Thrust Linear Motors and scales with direct feedback provides smooth, vibration-free table movement, which ensures improved positioning and cutting accuracy. Compared to ball-screws, backlash, lost motion and wear issues are eliminated, assuring long-term high precision performance.
- Minimum resolution of the linear scales is $0.01\mu\text{m}$ (0.00004 inch) contributing to ultra smooth and accurate finishes.

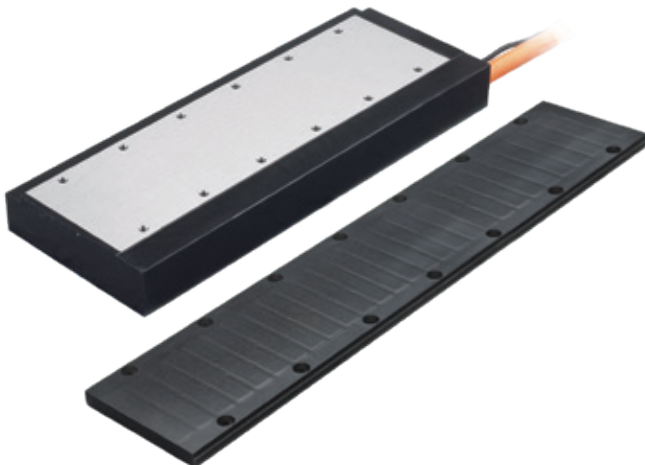

Auto Wire Threading

Reliable Auto Wire Threading System

- The YCM AWT is a simple, proven and reliable design that provides continuous unmanned operation day and night. This advanced technology enables re-threading within the kerf.
- Wire is annealed and guided by means of a water jet which can thread through workpieces up to 400mm.



High Speed Auto Wire Threading System

- Workpiece thickness 100mm.
- Annealing and cutting the wire takes 10 seconds.
- Threading the wire takes 10 seconds.

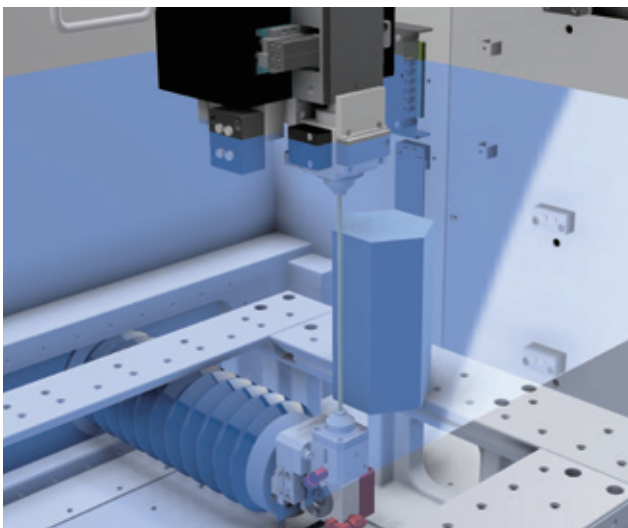

200mm submerged threading

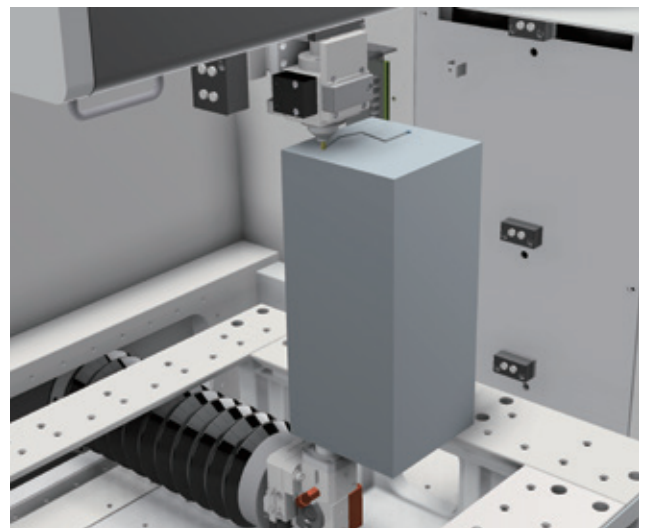

400mm thickness can re-thread within the kerf

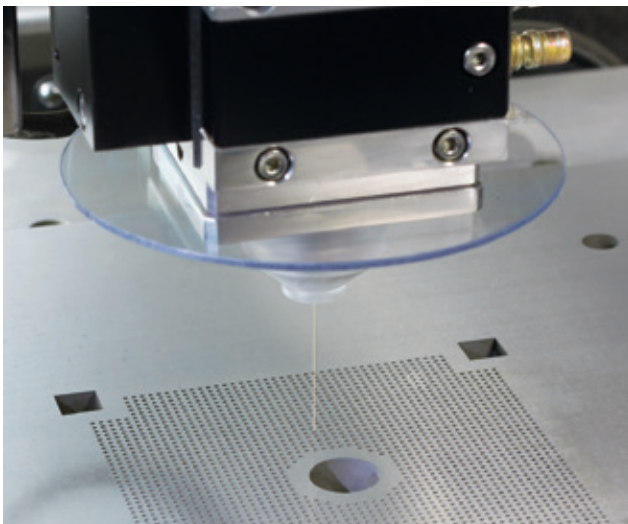

Material	SKD-11 Hardened Steel
Wire diameter / type	0.20 mm / Brass
Thickness	38 mm
Hole diameter	2.5 mm
Number of holes pre-drilled	3000
Dimensional accuracy	Within 5 µm
Wire threading success rate	100%

Controller and Generator System

The W6 Controller Is Designed to Deliver

- CNC Device: Industrial PC.
- CPU: 64-bit high speed CPU.
- Operation Interface: 19" LCD touch-screen, Keyboard, Mouse.
- Input Interface: LAN, USB driver, RS-232.
- Memory capacity: 32 GB SSD.
- Min. command unit: 0.0001 mm (0.000004").
- Max. programmable dimension: ±9999.9999 mm.
- Unit: Metric/Inch switchable.



User-friendly GUI



Workpiece set-up



Convenient feature function



Maintenance and diagnosis



Power Generator System

Discharge Frequency and Control

- The generator is designed to reduce system load and stabilize cutting conditions.
- ASIC chip technology is used to increase circuit stability and discharge performance.
- Real-time feedback of the discharge and cutting status is monitored and adjusted to reach optimum speed and accuracy.

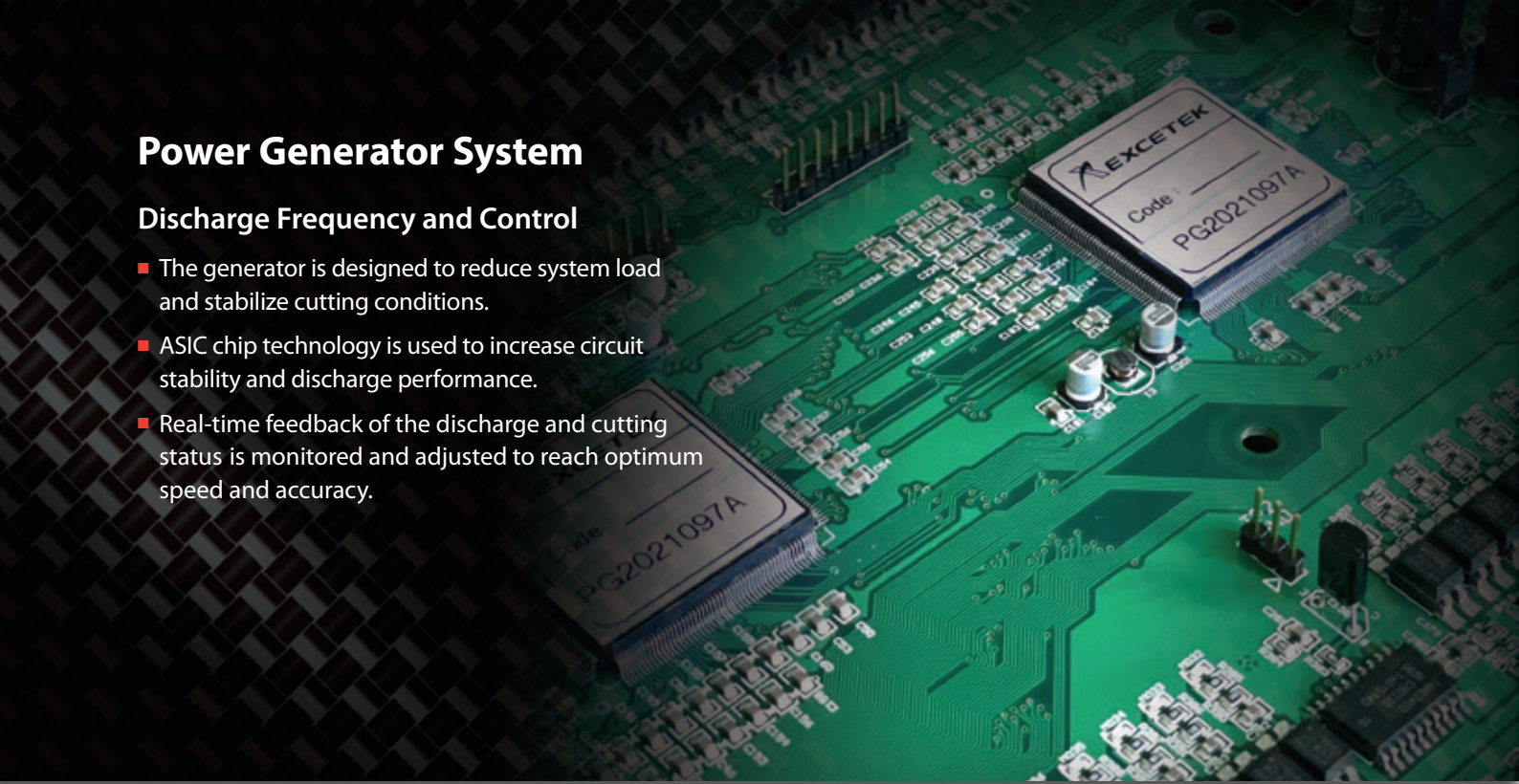

Electrolysis free cutting

The Power Generator is equipped with EF Technology which enhances cutting efficiency and speed, while nearly eliminating the effects of electrolysis during discharge.

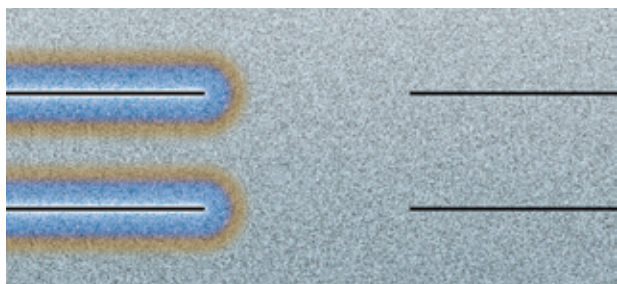

DC discharge

EF Technology - non-electrolysis discharge

RTS (Real Time Sparking)

Short response time provides feedback to ineffective discharges and adjusts conditions to improve cutting efficiency.

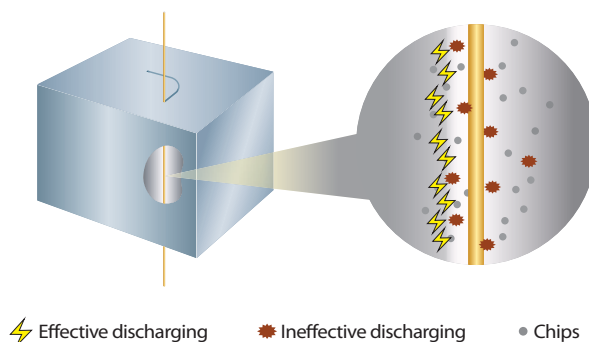

⚡ Effective discharging

★ Ineffective discharging

● Chips



Digital Power Management (DPM)

The Digital Power Management (DPM) system detects the discharge density, area, and capacity and automatically adjusts the power, wire tension and flushing to improve cutting speed while maintaining consistent accuracy through varying workpiece thicknesses.

DPM Technology Comparison Chart	Mode	With	without
	Speed condition	39 min	58 min
Accuracy condition	±3 μm	±15 μm	

Power Generator Corner Technology

Smart corner control

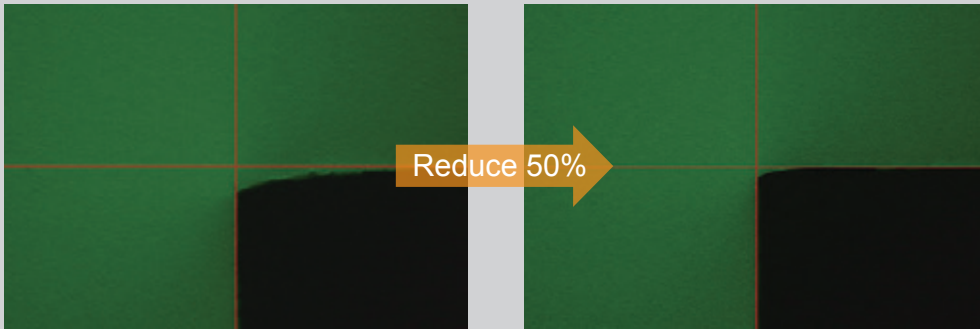

50% reduction in corner erosion

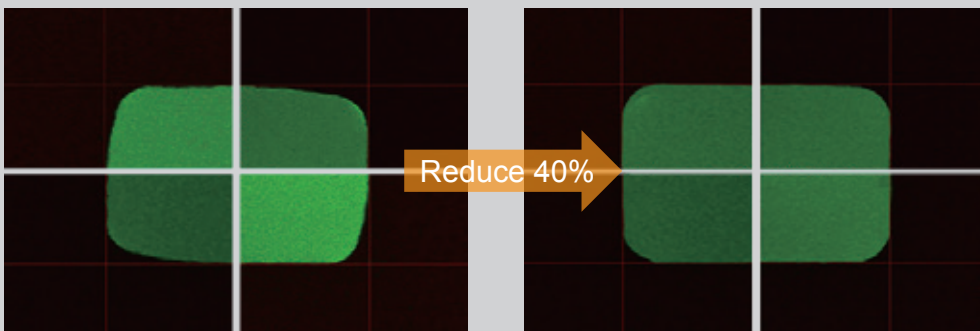

40% reduction in Shape error

Corner arc control

The square and circle shape error is controlled within 3 μ m

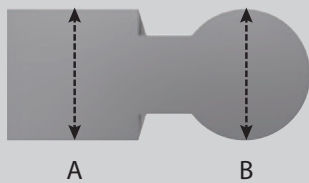

	Without control	With control
A	5.001 mm	5.001 mm
B	4.994 mm	4.999 mm
error	7 μ m	2 μ m

Corner break prevention

Wire breakage is reduced by 90% and cutting speed increased by 35%.

Discharge protection technology effectively prevents wire breakage during corner cutting.



Workpiece material: SKD -11 steel

- thickness: 100 mm
wire type: 0.25 mm brass wire
cutting speed: 150 mm²/min
- thickness: 50~80 mm
wire type: 0.3 mm brass wire
cutting speed: 250 mm²/min

Table Specifications

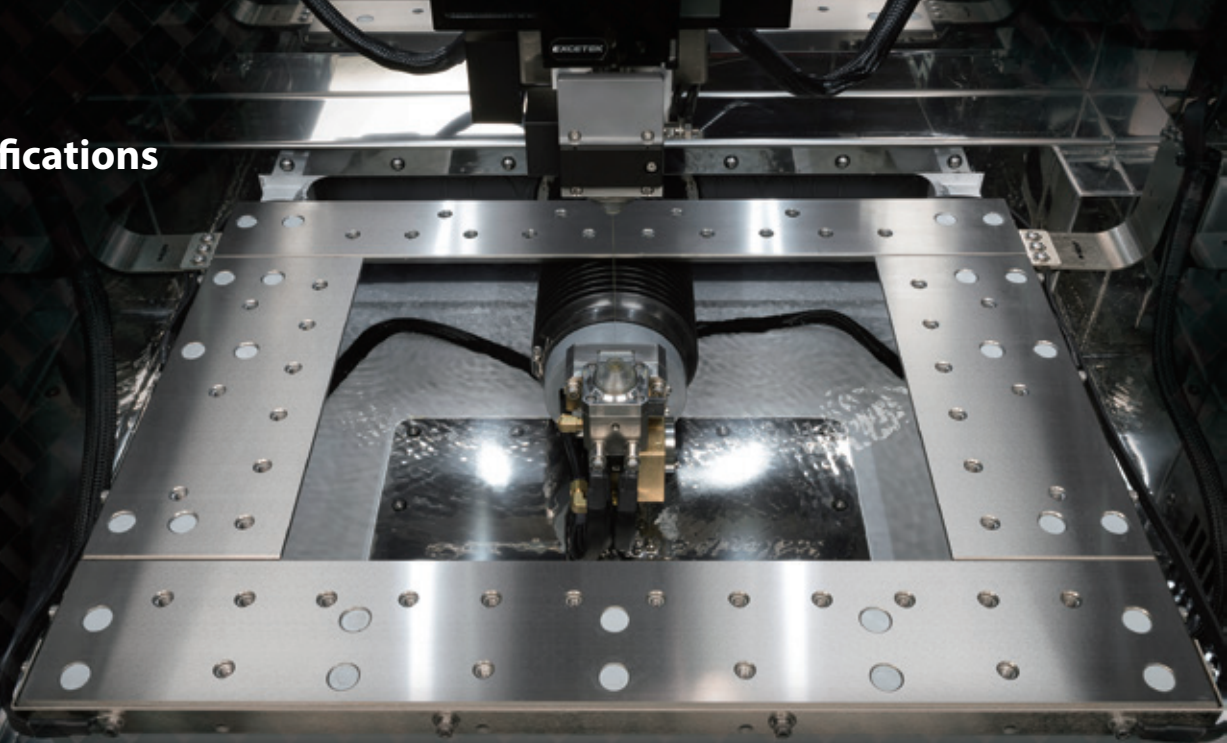

Four-Sided Hardened Stainless Steel Table

IMPULS 4

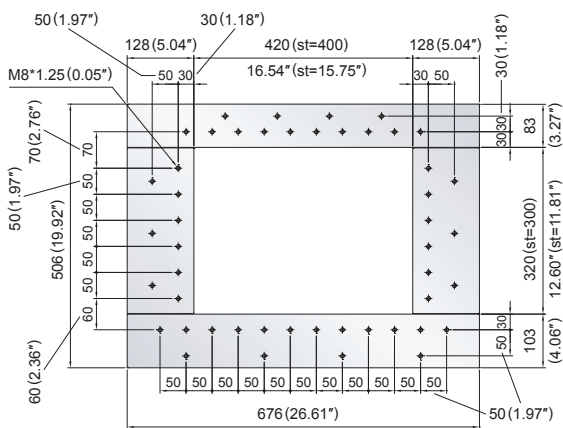

IMPULS 5

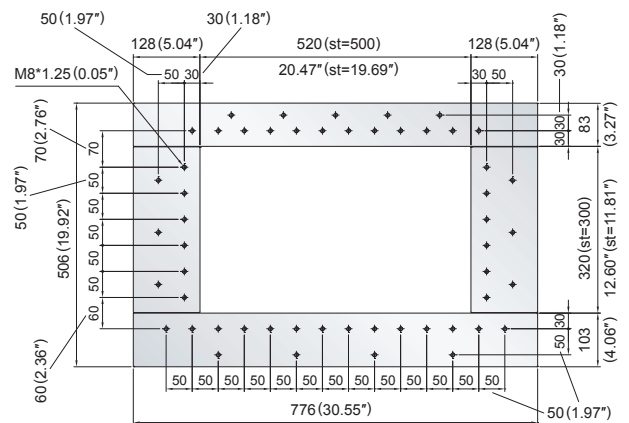

IMPULS 6

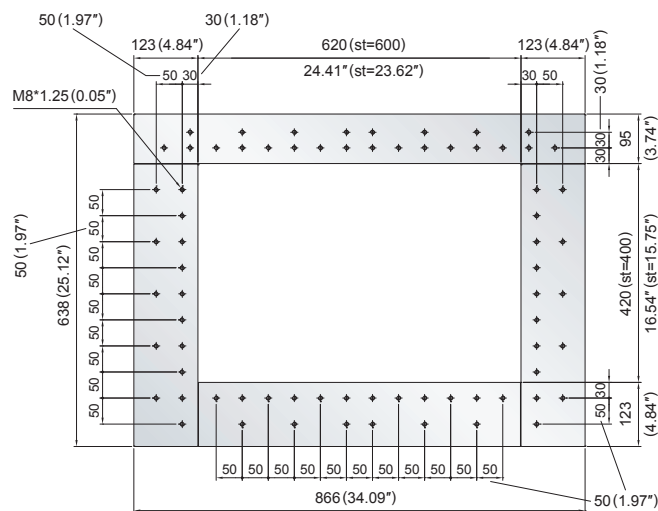

IMPULS 4



SUBMERGED TYPE

Machine	IMPULS 4
Max.work piece size	29.5" x 21.7" x 8.5" (750 x 550 x 215 mm)
Max.work piece weight	1102.3 lbs (500 kg)
Table travel of XY	15.7" x 11.8" (400 x 300 mm)
U&V axis travel	3.1" x 3.1" (80 x 80 mm)
Z axis travel	8.7" (220 mm)
Wire diameter	0.006" – 0.012" (0.15 ~ 0.3mm)
Number of axes controlled	XY axis linear motor, UVZ axis AC servo motor
Maximum taper angle	±22°/3.1" (80 mm) (wide diamond guide and nozzle)
Maximum cutting speed (option)	SKD 11 Hardened steel / 63.5mm thickness / 0.3mm Bedra Topas wire / 320mm ² /min
Machine dimensions	89.0" x 99.4" x 82.7" (2260 x 2525 x 2100 mm)
Machine weight	6724.1 lbs (3050 kg)

Dielectric Tank

Tank capacity	650 L
Paper filter	2/pcs
Deionizer	AUTO
Chiller unit	AUTO

Note: The manufacturer reserves the right to modify the design, specifications, mechanisms, etc. to improve the performance of the machine without notice. All specifications shown above are for reference.

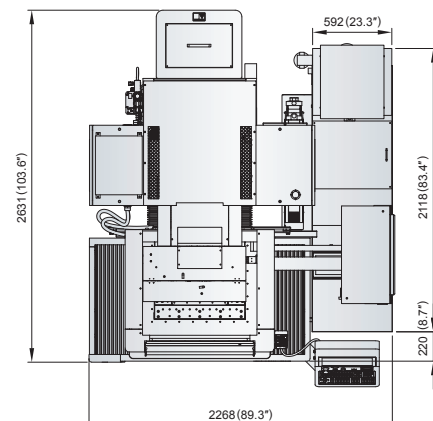
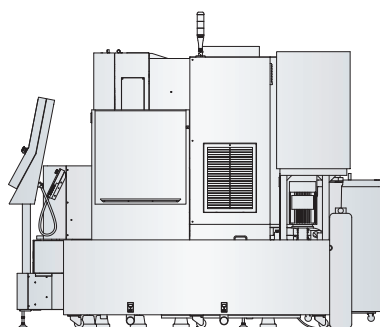
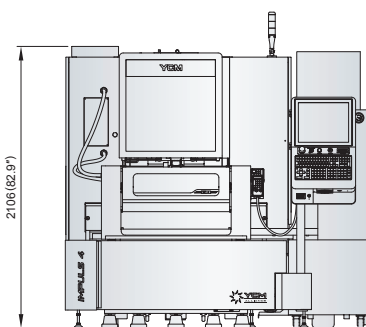

IMPULS 5



SUBMERGED TYPE

Machine	IMPULS 5
Max.work piece size	33.5" x 21.7" x 11.8" (850 x 550 x 300 mm)
Max.work piece weight	1322.8 lbs (600 kg)
Table travel of XY	19.7" x 11.8" (500 x 300 mm)
U&V axis travel	4.7" x 4.7" (120 x 120 mm)
Z axis travel	12.2" (310 mm)
Wire diameter	0.006" – 0.012" (0.15 ~ 0.3 mm)
Number of axes controlled	XY axis linear motor, UVZ axis AC servo motor
Maximum taper angle	±26°/3.9" (100 mm) (wide diamond guide and nozzle)
Maximum cutting speed (option)	SKD 11 Hardened steel / 63.5 mm thickness / 0.3 mm Bedra Topas wire / 320 mm ² /min
Machine dimensions	102.0" x 101.4" x 85.2" (2590 x 2575 x 2165 mm)
Machine weight	7385.5 lb (3350 kg)

Dielectric Tank

Tank capacity	750 L
Paper filter	2/pcs
Deionizer	AUTO
Chiller unit	AUTO

Note: The manufacturer reserves the right to modify the design, specifications, mechanisms, etc. to improve the performance of the machine without notice. All specifications shown above are for reference.

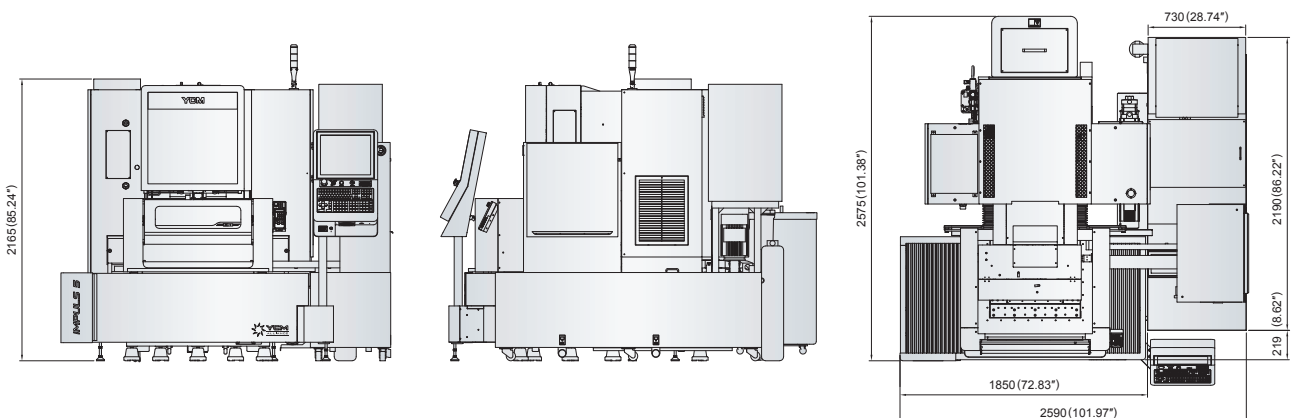

IMPULS 6



SUBMERGED TYPE

Machine	IMPULS 6
Max.work piece size	39.4" x 27.6" x 13.6" (1000 x 700 x 345 mm)
Max.work piece weight	1763.7 lbs (800 kg)
Table travel of XY	23.6" x 15.7" (600 x 400 mm)
U&V axis travel	6.3" x 6.3" (160 x 160 mm)
Z axis travel	13.8" / 16.1" (350 mm / 410 mm) (option)
Wire diameter	0.006" – 0.012" (0.15 ~ 0.3 mm)
Number of axes controlled	XY axis linear motor, UVZ axis AC servo motor
Maximum taper angle	±30°/3.9" (100 mm) (wide diamond guide and nozzle)
Maximum cutting speed (option)	SKD 11 Hardened steel / 63.5 mm thickness / 0.3 mm Bedra Topas wire / 320 mm ² /min
Machine dimensions	105.1" x 116.7" x 90.6" (2670 x 2965 x 2300 mm)
Machine weight	10361.7 lbs (4700 kg)

Dielectric Tank

Tank capacity	900 L
Paper filter	2/pcs
Deionizer	AUTO
Chiller Unit	AUTO

Note: The manufacturer reserves the right to modify the design, specifications, mechanisms, etc. to improve the performance of the machine without notice. All specifications shown above are for reference.

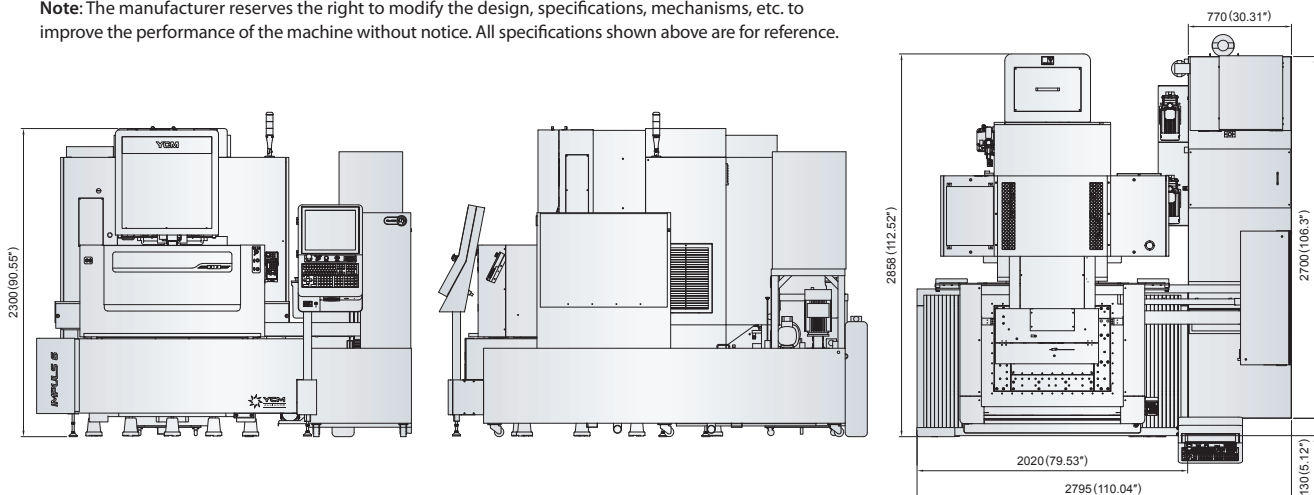



Make it Better, Together

www.YCMAlliance.com